

# MIDLAND® SECTION IV.b - AIR/HYDRAULIC UNITS

## MIDLAND AIR-HYDRAULIC UNITS SERIES I PRESSURE CONVERTERS

PART NUMBER: N4270CX  
PICTURED

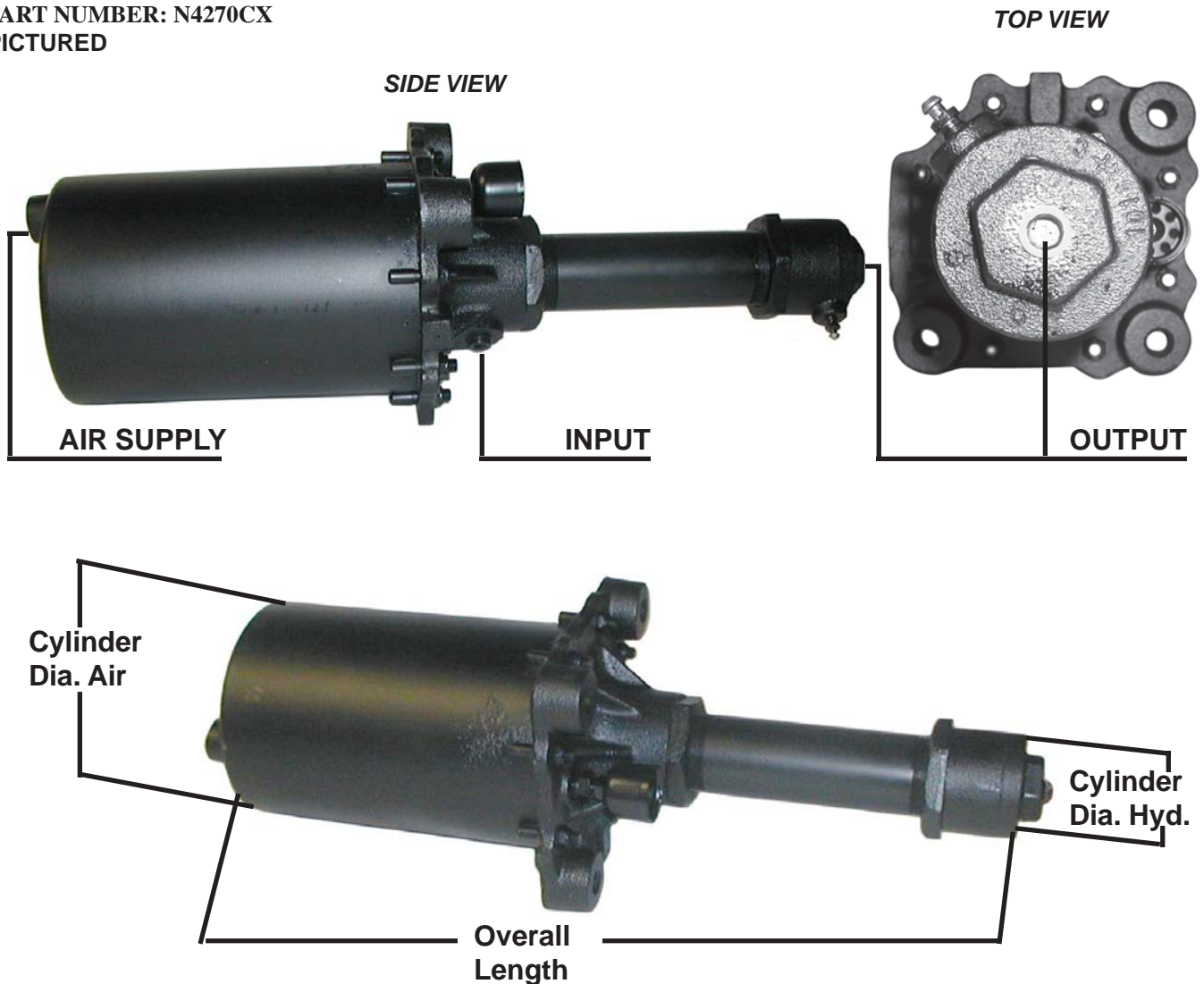

### PRESSURE CONVERTER INFORMATION TABLE REFERENCES (To Table on next page)

<sup>1</sup> FLUID TYPE:

B.F. = Brake Fluid

M.O. = Mineral Oil

<sup>2</sup> SWITCH TYPE = ELECTRIC OVERSTROKE INDICATION SWITCH

TYPE A - Normally open ground circuit switch.

TYPE B - Normally closed special circuit switch.

<sup>3</sup>NPTF = National Pipe Thread Fitting

# MIDLAND® SECTION IV.b - AIR/HYDRAULIC UNITS

## SERIES I PRESSURE CONVERTERS - Information Table

Part Number	Fluid Type <sup>1</sup>	Overall Length	Cy. Dia. Air	Cy. Dia. Hyd.	Switch Type <sup>2</sup>	Hydraulic Outlet Port	Hydraulic Inlet Port <sup>3</sup>
N4170FX	B.F.	22.81"	6.75"	1.75"	--	1/2-20 FLARE	3/8-18NPTF
N4170GX	B.F.	28.23"	6.75"	1.75"	--	1/2-20 FLARE	3/8-18NPTF
N4170LX	B.F.	22.81"	6.75"	1.75"	A	1/2-20 FLARE	3/8-18NPTF
N4170MX	B.F.	28.23"	6.75"	1.75"	--	9/16-18 O'RING	3/8-18NPTF
N4170RX	B.F.	22.81"	6.75"	1.75"	A	9/16-18 O'RING	3/8-18NPTF
N4174BX	B.F.	22.81"	6.00"	1.75"	--	1/2-20 FLARE	3/8-18NPTF
N4174EX	B.F.	22.81"	6.00"	1.75"	A	1/2-20 FLARE	3/8-18NPTF
N4174FX	B.F.	22.81"	6.00"	1.75"	--	9/16-18 O'RING	3/8-18NPTF
N4190AX	B.F.	22.60"	6.75"	1.25"	A	1/2-20 FLARE	3/8-18NPTF
N4190CX	B.F.	28.20"	6.75"	1.25"	A	1/2-20 FLARE	3/8-18NPTF
N4190EX	B.F.	28.20"	6.75"	1.25"	A	9/16-18 O'RING	3/8-18NPTF
N4194X	B.F.	22.70"	6.00"	1.25"	A	1/2-20 FLARE	3/8-18NPTF
N4194BX	B.F.	18.69"	6.00"	1.25"	A	1/2-20 FLARE	3/8-18NPTF
N4194DX	B.F.	22.70"	6.00"	1.25"	A	7/16-18 O'RING	3/8-18NPTF
N4194EX	B.F.	22.70"	6.00"	1.25"	--	9/16-18 O'RING	3/8-18NPTF
N4270X	M.O.	22.81"	6.00"	1.75"	--	1/2-20 FLARE	3/8-18NPTF
N4270CX	M.O.	22.81"	6.00"	1.75"	--	9/16-18 O'RING	3/8-18NPTF
N4270EX	M.O.	22.81"	6.00"	1.75"	--	9/16-18 O'RING	3/8-18 O'RING
N4270FX	M.O.	22.81"	6.00"	1.75"	A	1/2-20 FLARE	3/8-18NPTF
N4274X	M.O.	28.23"	6.75"	1.75"	--	9/16-18 O'RING	3/8-18NPTF
N4274AX	M.O.	22.81"	6.75"	1.75"	--	1/2-20 FLARE	3/8-18NPTF
N4274BX	M.O.	22.81"	6.75"	1.75"	--	3/8-18NPTF	3/8-18NPTF
N4274DX	M.O.	22.81"	6.75"	1.75"	--	9/16-18 O'RING	3/8-18NPTF
N4274EX	M.O.	22.81"	6.75"	1.75"	A	1/2-20 FLARE	3/8-18NPTF
N4274FX	M.O.	17.09"	6.75"	1.75"	A	9/16-18 O'RING	3/8-18NPTF
N4274KX	M.O.	22.81"	6.75"	1.75"	A	9/16-18 O'RING	3/8-18NPTF
N4274LX	M.O.	28.23"	6.75"	1.75"	A	9/16-18 O'RING	3/8-18NPTF
N4286AX	M.O.	23.89"	6.00"	2.62"	B	7/8-14 O'RING	9/16-18 O'RING
N4286BX	M.O.	17.87"	6.00"	2.62"	B	7/8-14 O'RING	9/16-18 O'RING
N4287X	M.O.	23.56"	6.75"	2.62"	B	7/8-14 O'RING	9/16-18 O'RING
N4287AX	M.O.	29.64"	6.75"	2.62"	B	7/8-14 O'RING	9/16-18 O'RING
N4287BX	M.O.	29.64"	6.75"	2.62"	A	7/8-14 O'RING	9/16-18 O'RING
N4288X	M.O.	22.52"	6.00"	2.00"	A	9/16-18 O'RING	3/8-18NPTF
N4290AX	M.O.	22.66"	6.75"	1.25"	A	1/2-20 FLARE	3/8-18NPTF
N4290BX	M.O.	28.20"	6.75"	1.25"	A	1/2-20 FLARE	3/8-18NPTF
N4290CX	M.O.	28.20"	6.75"	1.25"	A	9/16-18 O'RING	3/8-18NPTF
N4290DX	M.O.	28.20"	6.75"	1.25"	A	3/8-18NPTF	3/8-18NPTF
N4294X	M.O.	22.70"	6.00"	1.25"	A	1/2-20 FLARE	3/8-18NPTF
N4294BX	M.O.	22.70"	6.00"	1.25"	--	9/16-18 O'RING	3/8-18NPTF
N4294DX	M.O.	22.70"	6.00"	1.25"	A	9/16-18 O'RING	3/8-18NPTF
N4294EX	M.O.	22.70"	6.00"	1.25"	--	9/16-18 O'RING	9/16-18 O'RING

# MIDLAND® SECTION IV.b - AIR/HYDRAULIC UNITS

## SERIES II PRESSURE CONVERTERS

PART NUMBER	FLUID TYPE <sup>1</sup>	OVERALL LENGTH	CYLINDER DIA. AIR	CYLINDER DIA. HYD.	SWITCH TYPE <sup>2</sup>	HYDRAULIC OURLET PORT
N4185CX	B.F.	17.19"	4.50"	1.125"	A	1/2-20 FLARE
N4185EX	B.F.	13.20"	4.50"	1.125"	A	1/2-20 FLARE
N4185GX	B.F.	13.20"	4.50"	1.125"	B	1/2-20 FLARE
N4185JX	B.F.	17.19"	4.50"	1.125"	A	1/2-20 UNF-2B
N4195AX	B.F.	13.10"	4.50"	1.250"	A	5/8-18 FLARE
N4195BX	B.F.	13.10"	4.50"	1.250"	B	5/8-18 FLARE
N4285X	M.O.	17.19"	4.50"	1.125"	A	1/2-20 FLARE
N4285AX	M.O.	13.20"	4.50"	1.125"	A	1/2-20 FLARE
N4295BX	M.O.	17.19"	4.50"	1.250"	B	1/2-20 FLARE
N4295DX	M.O.	17.19"	4.50"	1.250"	A	9/16-18 O'RING
N4295EX	M.O.	17.19"	4.50"	1.250"	B	9/16-18 O'RING

### <sup>1</sup> FLUID TYPE:

B.F. = Brake Fluid  
M.O. = Mineral Oil

View from Top

OUTPUT



N4185CX  
Pictured

Side View

AIR SUPPLY



INPUT

### <sup>2</sup>SWITCH TYPE = ELECTRIC OVERSTROKE INDICATION SWITCH

TYPE A - Normally open ground circuit switch.  
TYPE B - Normally closed special circuit switch.

## SERIES III PRESSURE CONVERTERS

**KN35010X**  
(Older Style)

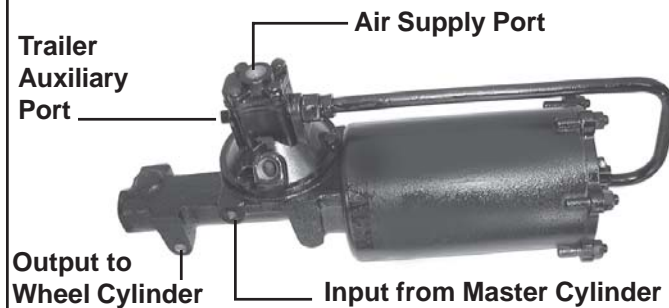

Note: No Residual Check Valve

**KN35020X**  
(Older Style)

Residual Check Valve Included  
4 1/2" Diameter Air Cylinder



## SERIES IV PRESSURE CONVERTERS

**KN35010AX**  
HAS NO RESIDUAL CHECK VALVE

**KN35020AX**  
RESIDUAL CHECK VALVE INCLUDED

Top View



Side View



Overall Length: 14"